

PARTS LIST			
ITEM	QTY	PART NUMBER	DESCRIPTION
1	1	050DU	1/2" Coupler x 1/2" Female Thd, Unbagged
1.1	1	050MXD	Machined 1/2" Coupler x 1/2" Female Thd
1.2	1	100DECAL	Mini Coupling Decal
1.3	1	75G	COUPLING GASKET
1.4	2	75K	1" CAM ARM W/ RING
1.5	2	75P	CAM ARM PIN

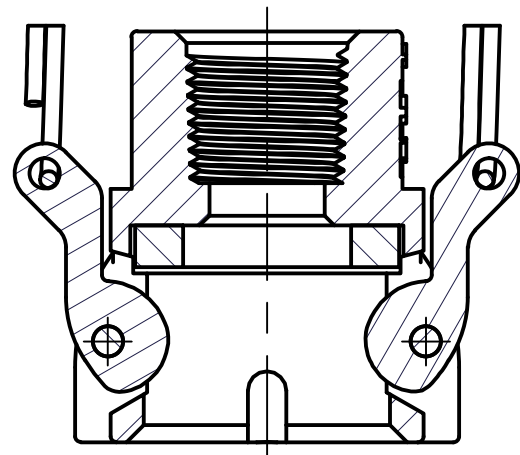

SECTION A-A
SCALE 1:1

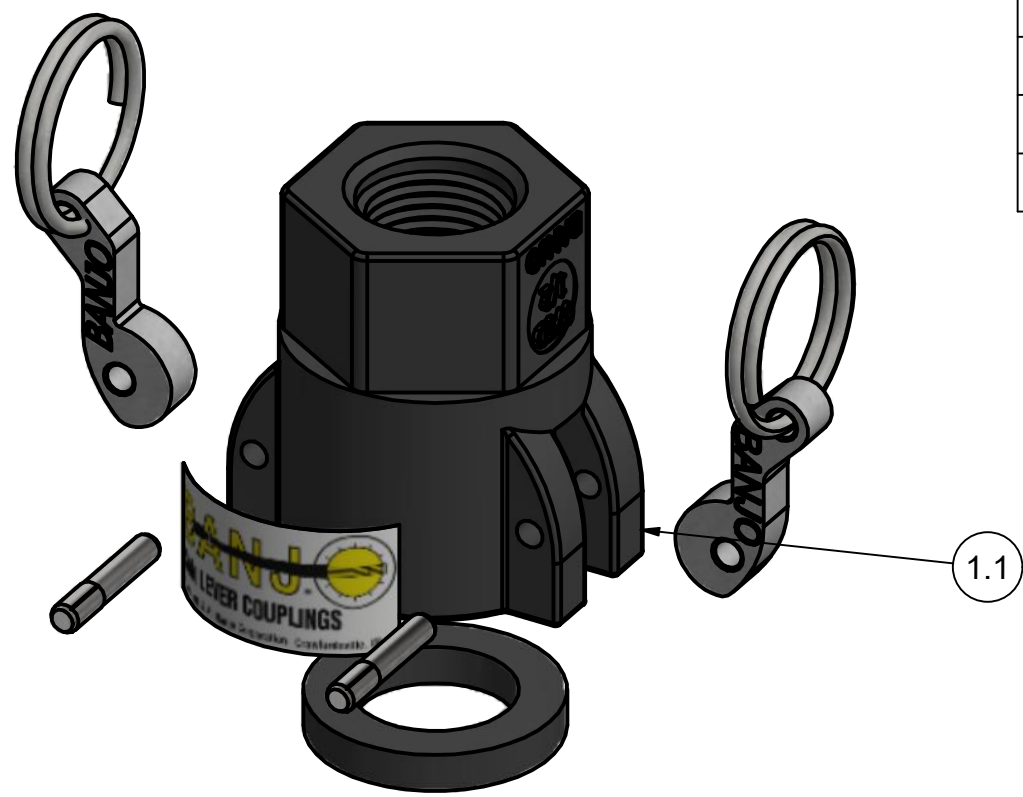
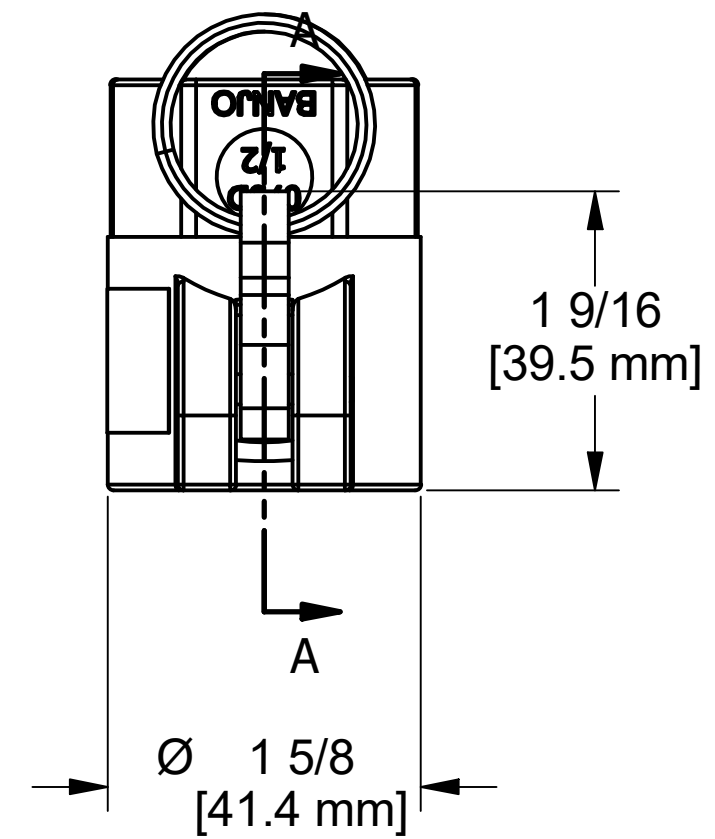
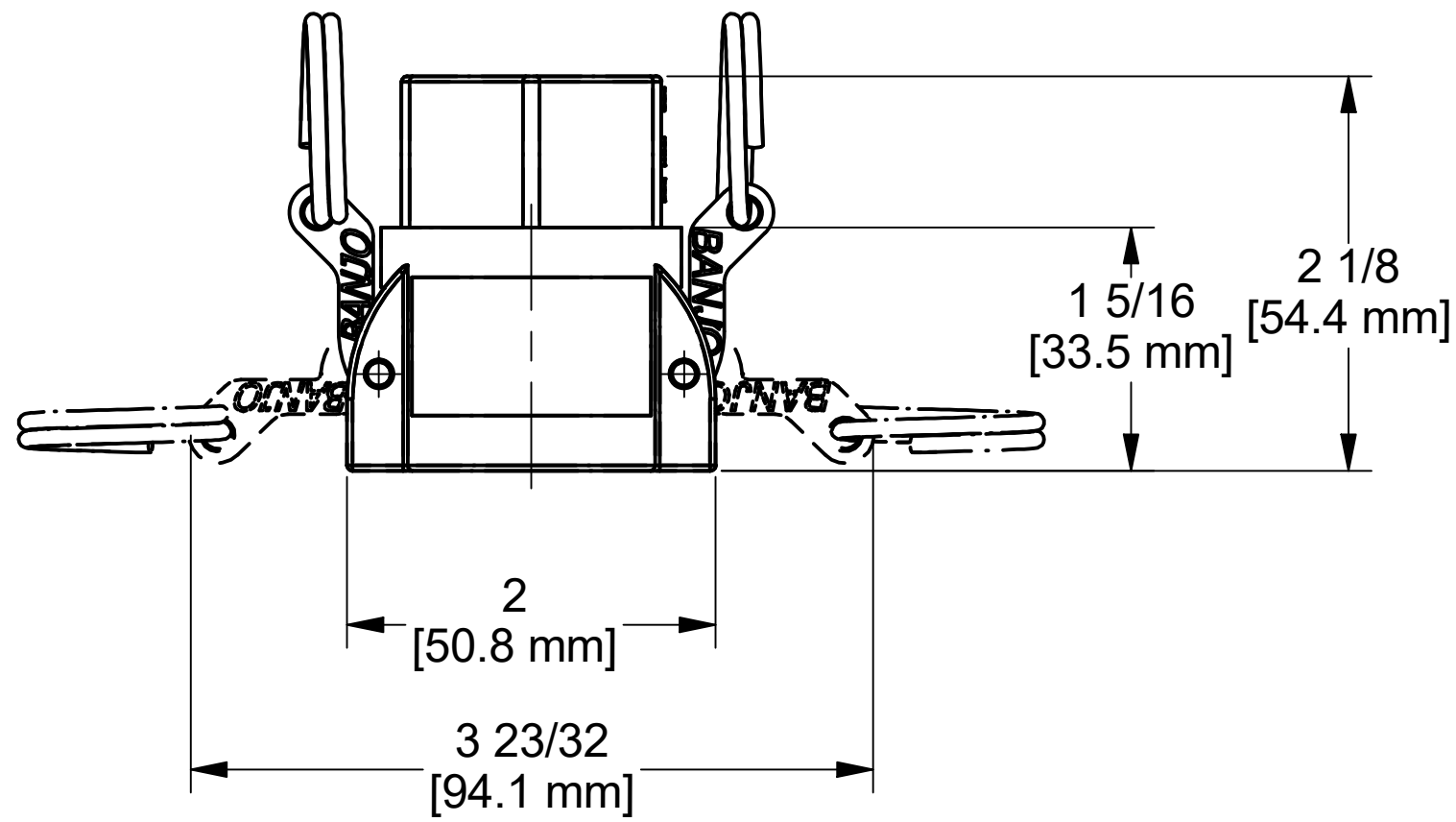

THIS DRAWING AND ALL INFORMATION CONTAINED THEREON ARE THE EXCLUSIVE PROPERTY OF BANJO CORPORATION.

UNLESS SPECIFICALLY NOTED, THIS DRAWING AND ITEMS SHOWN ON THIS DRAWING ARE SUBJECT TO CHANGE AT ANY TIME.

BANJO CORPORATION
150 BANJO DRIVE, CRAWFORDSVILLE, IN 47933
WEB SITE: WWW.BANJOCORP.COM
E-MAIL: BANJOSALES@IDEXCORP.COM

DESCRIPTION
1/2" Coupler x 1/2" Female Thd, Unbagged

PART NUMBER
050D

NOTE: PARTS ARE TO BE BAGGED.